

# WILLOWWOOD®

## ALPHA® CONTROL LINER SYSTEM INSTRUCTIONS FOR USE

### WHAT'S IN THE BOX

Alpha Control Liner with Electrodes Installed  
Alpha Control Module\*  
Alpha Control Liner Cap  
Alpha Control Lock with Release Button\* Alpha Control  
Liner Fabrication Dummy\*  
Alpha Control Module Removal Tool  
Instructions  
*\*not included with replacement liner*

### ADDITIONAL MATERIALS REQUIRED

Coapt Complete Control System  
Batteries  
Any additional desired components

# WILLOWWOOD®

WillowWood Global LLC  
15441 Scioto Darby Road  
Mt. Sterling, OH 43143  
USA  
telephone 740.869.3377 / 800.848.4930  
fax 740.869.4374  
patent [www.willowwood.com/patents](http://www.willowwood.com/patents)



Emergo Europe  
Westervoortsedijk 60  
6827 AT Arnhem  
The Netherlands





Symbol indicating to consult instructions for use.



Symbol indicating body contact.

**RX Only**

This device is only intended for sale to a licensed medical professional.



Symbol for general warning.



Caution: Federal law restricts this device to sale by or on the order of a physician.



The liner has been constructed using polymer materials to create a durable, lightweight, water-tight, and radio-transparent design. Polymers can melt or burn if exposed to high temperatures or flame. Do not expose your liner product to these conditions. Doing so may result in ignition resulting in injury or death.



This Alpha product is intended for use on a single patient. Use of the product with multiple patients could lead to cross contamination between patients.



**WARNING:** To avoid danger of suffocation, keep this product and its packaging away from babies or children.



Do not expose the liner to items to which the patient is allergic or otherwise sensitive. The liner could absorb the allergen or irritant and become a permanent source of exposure.



The electrodes are made with a stainless steel that contains nickel. Do not use the liner with patients who have a nickel sensitivity or allergy.



Dispose of this product in accordance with local regulations, or return it to the factory for proper disposal.



Use only electrodes ACL-300.



The liner system should not be used when the batteries of the prosthesis are being charged.



There are no field-serviceable parts inside the liner lock or module. Opening the liner lock or module may result in injury or death and will void the warranty.



Unauthorized changes or modifications to the liner lock or module or accessories may; impair their function resulting in injury or death, will void the warranty, and may prevent their compliance with relevant standards.



All liner components have passed safety testing for use as medical devices. Components of the Coapt Complete Control System that include radio enabled devices comply with United States and international guidelines for low power transceivers. If liner components, when used with the Coapt Complete Control System, will be used around safety critical devices such as pacemakers or defibrillators, consult the manufacturer for appropriate usage instructions. Failure to do so may result in injury or death. Consult the section on Regulatory Information for more information on safety and compliance.



Use of the liner at temperatures above 38°C (100 °F) may heat the surface of the product to unsafe temperatures which could cause burns with extended contact. Use care when using the liner in high temperature environments.



Electrical equipment can interact. Do not operate the liner system while it is stacked upon, or in close proximity to, other electrical equipment without monitoring performance. Doing so may result in equipment malfunction or failure.



The Alpha Control Liner System is designed to work specifically with the Coapt Complete Control System. Use of the Alpha Control liner System with other products may result in harm to the device, the user, or both, may void the warranty, and may negatively affect performance and/or compliance.



# CONTENTS

SECTION .....	PAGE
INDICATIONS FOR USE.....	4
DONNING.....	4
TURNING ON THE SYSTEM.....	5
TRIMMING.....	5
CLEANING AND CARE.....	6
ALPHA CONTROL MODULE INSTALLATION.....	8
SHAPE CAPTURE AND MODIFICATION.....	11
TEST SOCKET FABRICATION.....	13
TEST SOCKET FITTING.....	15
DEFINITIVE SOCKET FABRICATION.....	17
REPAIRING WORN SEAMS.....	19
TROUBLESHOOTING.....	19
REGULATORY INFORMATION.....	22

## INDICATIONS FOR USE

The Alpha Control Liner System is to be used exclusively for exoprosthetic fittings of the upper limbs.

## DONNING

-  Do not apply any type of lotion or powder to the residual limb or to the liner, as these products could damage the liner.
-  The residual limb should be clean, dry, and free of soap residue.
-  Cover open wounds or non-intact skin with a bandage or other appropriate dressing to avoid direct contact between the wound and the liner.

1. Invert the liner so that the gel side is facing out.
2. Check that all electrodes are correctly installed:
  - Electrodes should be finger tight and flush with the gel. Do not overtighten.
  - The electrodes must be fully inserted in order to decrease signal noise. Electrodes are fully inserted when flush with the gel while the liner is flat. If a gap is present between the electrodes and the gel, continue to finger tighten until fully seated.

**Note:** The gel surface should be flat when checking if electrodes are completely installed (Figure 1). When the liner is not flat, the gel may appear to stretch away from the electrodes (Figure 2). Tightening the electrodes in this configuration can damage the electrodes or the liner.

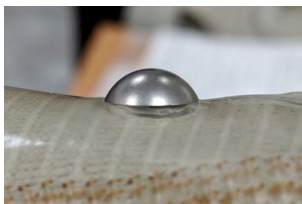

Figure 1



Figure 2

3. Place the end of the liner against the end of the limb. Center the umbrella on the distal end of the limb.
4. Carefully roll the liner onto the residual limb. Ensure electrodes do not contact bony prominences.

For transradial users, don the liner so that the seam runs posterior to the elbow and slightly lateral.

The seam should run between the olecranon process and the lateral epicondyle (Figure 3).



Figure 3

**Note:** When replacing a liner with a new liner:

- Remove the module from the old liner and install it in the new liner. Refer to the Alpha Control Module Installation section (page 8) for further details.

## TURNING ON THE SYSTEM

To turn on the system:

1. Don the liner and socket.
2. Turn on the power.



**Powering on the system before the liner is engaged with the lock will cause an error and lack of communication between the Alpha Control Liner System and Coapt Complete Control System. A red LED will display from the lock.**

## TRIMMING

Trim the liner to a shorter length if desired for patient comfort.

- Never cut the liner distal to the electrodes.

Use sharp scissors, a paper cutter, or a Hand-Held Cutting Wheel (WillowWood Part No. 700- TL002). If using the Hand-Held Cutting Wheel, place the liner on a cutting board or thick piece of plastic. Using a straight edge as a guide, roll the cutting wheel cross the liner.

### **To help prevent the seam from unraveling:**

Place a small drop of instant adhesive\* on the seam directly below the trimmed edge

### **Repairing an unraveling seam:**

Place a small drop of instant adhesive\* on the seam directly below where the liner has begun to unravel

\* *Before the instant adhesive completely soaks into the seam, apply a drop of accelerant directly on top of the adhesive.*

**Note:** If you do not apply any accelerant to the instant adhesive, be sure to wait until the instant adhesive sets up before using the liner.

## CLEANING AND CARE

Proper hygiene is extremely important when using the liner. Please review these care instructions very thoroughly with the patient.

### Daily Cleaning

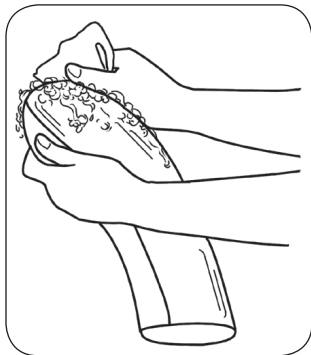

Thoroughly clean the gel side of the liner. Use lukewarm tap water and a hypoallergenic body soap. Apply soap with a clean, soft cloth or sponge.

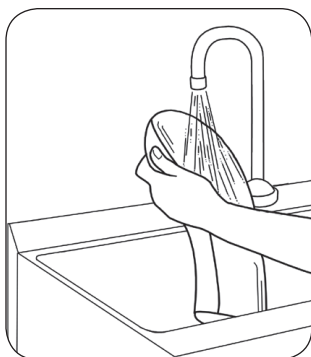

Rinse **all** soap residue from the liner with water, paying special attention to the areas around the electrodes.

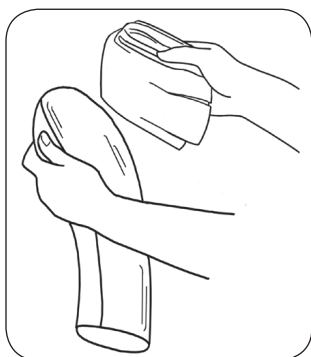

Dry the liner with a clean, lint-free cloth.

**Notes:** Do not scrub the liner. Scrubbing can roughen the surface of the liner, which can then irritate the skin.

Do not submerge the liner in any liquid.

Do not remove the electrodes for cleaning.

**Caution:** Drying the liner with the gel side facing out will damage the liner.

If washing the liner fabric is desired, take care to cover and protect the distal housing and module from exposure to moisture.

## Weekly Disinfection



Place a small amount of ethyl or isopropyl alcohol on a soft, clean cloth.

Gently wipe the gel side of the liner for two minutes.

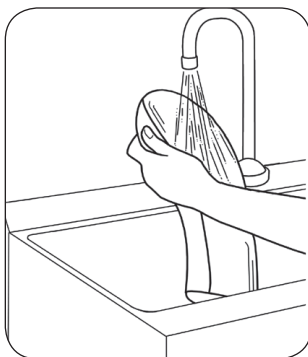

Rinse off excess alcohol with water.

Dry the liner with a clean, lint-free cloth.

**Note: Do not immerse the liner in ethyl or isopropyl alcohol. Extended contact in large amounts will stiffen the liner gel.**

## Daily Inspection of the Liner

Explain to the patient that every liner should be inspected after each day of use for the following conditions:

- Any signs of damage or unusual wear, which may indicate changes in the prosthetic fit.
- Loose electrodes.
- Rough electrode surfaces or other damage that might cause skin irritation.
- Separation of the electrodes from the liner.
- Separation of the plastic cap under the electrodes.
- Abrasion in the fabric around the electrodes and leads. Wearing a liner with exposed electrodes or leads can cause an electric shock if the liner contacts a source of electricity.

If any of these conditions are observed, the patient should stop wearing the liner and contact you immediately.

## Perspiration

Any amputee that engages in an activity that could result in excessive perspiration should be instructed to periodically remove the liner and dry off the liner and residual limb to prevent slippage of the liner on the limb, and to dry the lock by gently patting the inside of the socket with a microfiber cloth.

## Storage

When the liner is not being worn, it should be stored with the fabric side out in a cool, dry place. If the liner will not be used for an extended period, cover the dry liner with a clean plastic bag.

# ALPHA CONTROL MODULE INSTALLATION

Each Alpha Control Liner requires that an Alpha Control Module be installed for functionality. The liner will eventually need to be replaced, but the module, can be transferred to the replacement liner.

## Important:



**Use only electrodes ACL-300.**



**Use care when inserting or removing the module to avoid damage.**

## To remove the Module from an old liner:

1. Unscrew the liner cap and set it aside. If necessary, use an adjustable wrench on the flat side section of the liner cap to start removal. Do not use a wrench that has teeth, as this can damage the liner cap. Do not scratch the top surface of the liner cap, or you may need to replace it to ensure system functionality.
2. Use the included module removal tool or a pair of internal retaining ring pliers (with .09" diameter right angle tips) to grasp the module by the half- circle indentations. Make sure to place the tool as far into the Module locating keys as possible before grasping, so that the top edge of the Module does not get damaged (Figure 4).



Figure 4



**Do not use needle nose pliers as the angled approach may damage the module.**

3. Gently pull the Module straight out of the housing, without rotating or bending the Module (Figure 5)
4. Carefully set the Module to the side, making sure not to crush or scratch any of the exposed electronic components or the metal rings on the top surface.



Figure 5

To install the Module in a new liner:

1. Unscrew the liner cap, if it is in place, and set aside. If necessary, use an adjustable wrench on the flat side section of the liner cap to facilitate removal. Do not scratch the top surface of the liner cap, or you may need to replace it to ensure system functionality.
2. Inspect the Module (Figure 6) and the inside of the Module housing (Figure 7) for any dirt or debris that may have accumulated. Blow with compressed air to remove any debris.

If necessary, rinse with isopropyl alcohol and let air dry completely before continuing. Do not allow acetone to contact the Module.



Figure 6: Module



Figure 7: Inside module housing

3. Both the Module housing and the Module have locating keys (Figure 8a). Align the Module housing key with the Module key, making sure that the metal rings are facing out of the housing (toward you).

Note that the Module has two locating keys: One extends the entire length of the Module (Figure 8b), and one extends halfway down the Module (Figure 8c). The key that aligns with the liner is the one that extends the full length of the Module (Figure 8b).



Figure 8a



Figure 8b:  
Align with the key  
in the Module housing



Figure 8c:  
Align opposite the key  
in the Module housing

4. Gently begin to push the Module into the housing (Figure 9), without rotating or bending the Module. The Module should easily slide into place in the housing. If it does not, check that the keys are aligned (note that the Module has a second semi-circular groove that does not continue the entire length, and should be positioned opposite the key).



Figure 9

5. You should feel a click when the Module is completely seated in the housing (Figure 10). The edge of the Module should be flush with the Module housing. If the edge of the Module is not flush with the housing, the Module is not yet completely inserted.

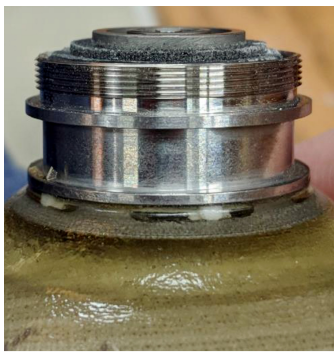

Figure 10

6. When the Module is fully seated, screw on the liner cap. Finger-tighten only; do not over-tighten.



**Do not screw down the liner cap before the Module is seated flush with the top of the housing. Doing so can crush the Module or its connector.**

## SHAPE CAPTURE AND MODIFICATION

1. Don the liner with the electrodes installed. Ensure that there are no wrinkles or air pockets between the skin and the liner.
2. Fill in the groove on the umbrella using the provided rubber bands (Figure 11). The rubber should be flush with the metal surface above and below the groove.

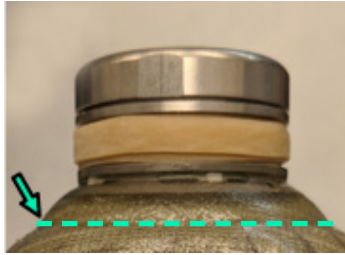

Figure 11

Notice the umbrella transition line (arrows in Figure 11), which is the point where the umbrella changes from the straight edge to a curved, traditional umbrella shape. This line will be referenced in Step 9.

If you are scanning the limb rather than casting, proceed to Step 9.

3. Wrap the limb and liner with plastic wrap or equivalent protective material.
4. Pull a casting sock over the limb (Figure 12). Keep the casting sock tight with the help of a suspender.
5. Make any desired reference marks with an indelible pencil.
6. Using standard casting principles, apply plaster bandage (Figure 13). To ensure proper lock orientation, be sure to incorporate the base of the umbrella in the plaster wrap.



Figure 12

7. Remove the plaster negative after it has set. Clean the residual limb and the liner with lukewarm water.
8. Prepare the positive plaster model.



Figure 13

9. Make any smoothing or modifications to the positive model.
  - We recommend avoiding aggressive anatomical contours and using a global reduction of no more than 3%.
  - The lock and umbrella need to align in order for the lock to engage. Because of this, a rigid triceps bar can impede the amputee's ability to don the socket. We recommend forgoing a rigid triceps bar. If a triceps bar is desired, a compliant material such as an adjustable strap should be used.

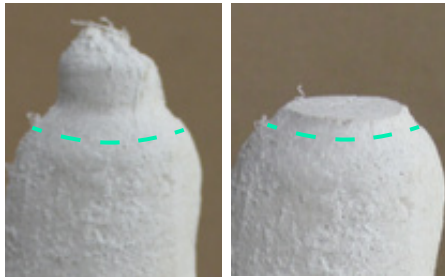

Figure 14a

Figure 14b

10. Sand down the distal end of the positive model to the umbrella transition line to create a flat surface on which to place the lock dummy (Figures 14a, 14b).

11. Place the lock dummy on the model with the hole for the lock release button in the desired orientation (Figure 15). Attach the lock dummy to the model with the provided screws.

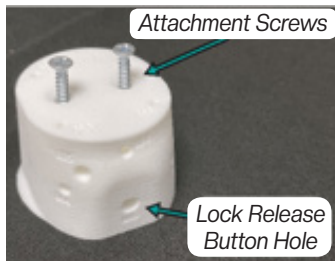

Figure 15

12. Blend the dummy to the positive model. To allow the lock to be dropped into place, make sure there are no undercuts (Figures 16a, 16b).



Figure 16a

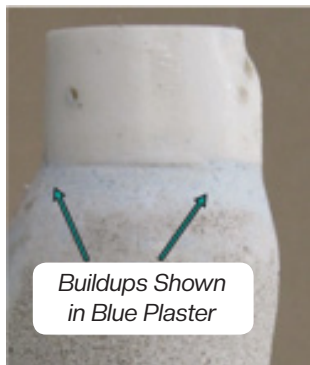

Figure 16b

## TEST SOCKET FABRICATION

Note: The lock dummy is shipped with all available screws installed. The first time you use the lock dummy, you will need to remove the screws you don't need.

- If you will be mounting the lock from the distal end of the socket, you will need to remove the side screws. The side M4 screws can be removed with a 2 mm hex wrench. Your dummy should look like the one shown in Figure 17a.
  - If you will be mounting the lock from the side of the socket, you will need to remove the distal screws. The distal M3 screws can be removed with a 1.5 mm hex wrench. Your dummy should look like the one shown in Figure 17b.
1. The lock can be attached to the socket from the distal end or from the side. A side mount may be desired if build length is a concern.

Note: Install set screws completely into the appropriate hole. Hole depths were designed for a socket wall thickness of 1/8" (.125"). Be careful not to strip the threaded holes in the dummy.

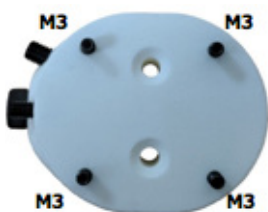

Figure 17a

For **distal mounting**, use a 1.5 mm hex wrench to insert the 4 provided **M3** set screws into the top holes of the dummy (Figure 17a).



Figure 17b

For **side mounting**, use a 2 mm hex wrench to insert the 4 provided **M4** set screws into the side mount holes of the dummy (Figure 17b).

Note: The following photos will show side mount installation.

- For **all sockets**, add the following screws (Figures 17c, 17d):
  - Use a 2 mm hex wrench to insert one **M4** set screw into the LED indicator hole.
  - Use a 5 mm hex wrench to insert the **M6** socket head cap screw into the lock release button hole.
  - Use a 2.5 mm hex wrench to insert the **M5** screw into the connection cable hole.

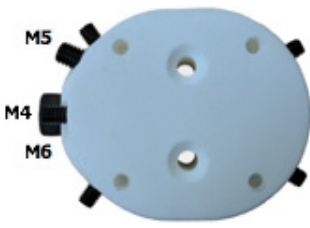

Figure 17c



Figure 17d

2. Fabricate the diagnostic socket.
3. Grind down to expose the screws. Remove the screws. If using the side mount screws, continue to grind around the side mount holes until the socket thickness is less than 1/8" (.125") to ensure the proper amount of thread engagement when installing the lock.
4. Cut trim lines and remove the cast and the lock dummy from the socket.
5. Using a 5/16" (8 mm) drill bit, drill the connection cable hole.
6. Using a 5/8" (16 mm) drill bit, drill the lock release button hole.
7. Buff the trim lines and insert the lock. Hold the lock in place with the provided screws:
  - For distal mounting, use a 2 mm hex wrench to install the (4) M3 screws.
  - For side mounting, use a 2.5 mm hex wrench to install the (4) M4 screws.

Make sure to route the connection cable out through the connection cable hole (Figure 18).

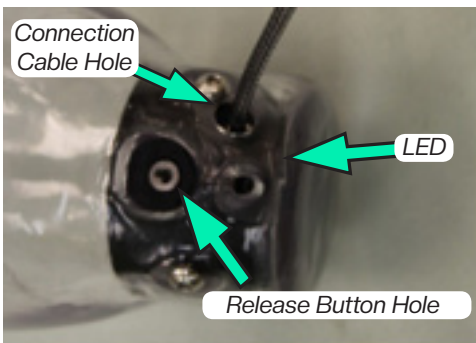

Figure 18

8. Screw the lock release button into place (Figure 19). **Be careful not to cross-thread or over-tighten.**

Ensure the button operates freely. If necessary, remove the lock body and enlarge the hole.



Figure 19

## TEST SOCKET FITTING

1. Have the amputee don the liner.
2. Have the amputee don the test socket. The lock should make a clicking noise to indicate complete donning, at which point a gentle tug can confirm that the lock is engaged. Make adjustments as necessary for easy donning. Remove lock or cover with tape prior to grinding the socket to keep debris out of connector.
3. Attach the Coapt System cables according to the Coapt guidelines:
  - a. Remove this Plug.



Figure 20

- b. Attach the device interface cable to the Coapt controller (Figure 21).



Figure 21

- c. Attach the lock connection cable to the port shown in Step 4a (Figure 22). Ensure the white indicator mark is on the right side when viewing the device cable in an upright position. The system should now be assembled as shown in Figure 23.

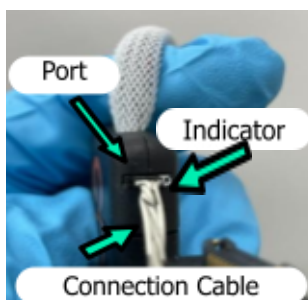

Figure 22

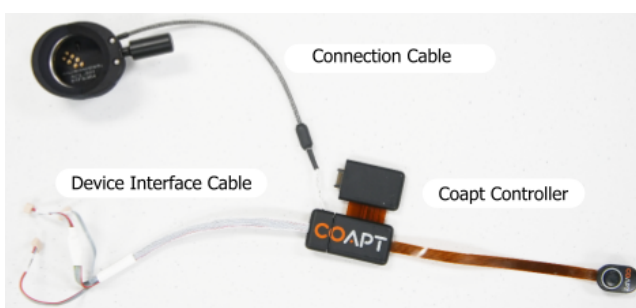

Figure 23

- d. If attaching to integrated Coapt controller board of the Espire elbow, open the cover and pass the lock connection cable through the main opening before plugging the connector into the board (Figure 24). The white indicator on the lock cable should be on the right side (Figure 25).

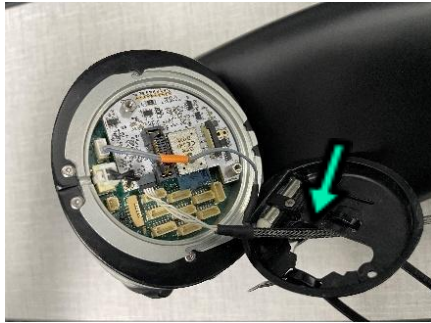

Figure 24

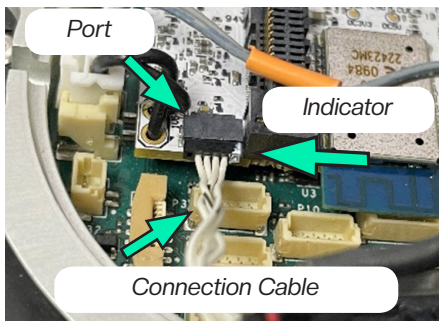

Figure 25

- e. To ensure no movement between the connector and the Espire board, the white section of the lock cable can be tied to the adjacent black wires using a cable tie as shown in Figure 26. Excess slack is maintained below the zip tie to prevent strain on the connector.

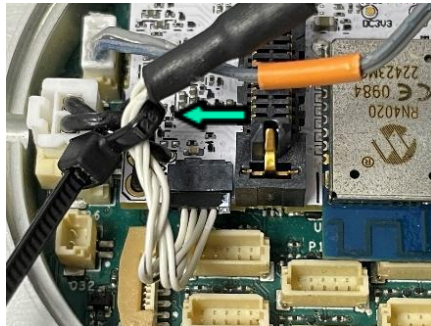

Figure 26

- f. Once tighten, the tag of the zip tie should be cut and the cover secured over the board and connection (Figure 27).

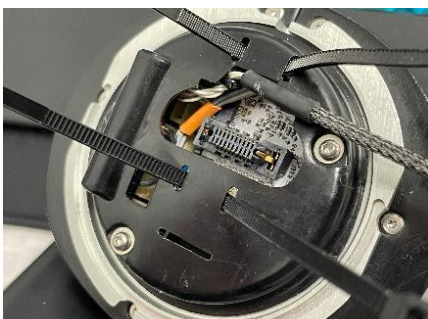

Figure 27

**Note: For Steps 4-7, the terminal device should not be attached to the socket. This will allow for easier troubleshooting should any issues arise during first test fitting.**

4. Attach the terminal device on a stand or lay the terminal device on a table. Make sure all connections are completed.
5. Engage the liner with the lock, then power on the prosthesis. Receive a short beep and momentary green light flash on the Complete Calibrate Button. Receive a green light from the lock LED, this turns off after ~3 seconds. Refer to the **Coapt COMPLETE CONTROL SYSTEM Gen2 Handbook** more information on the various light and sound patterns made by the Coapt Calibrate Button. Calibrate the Coapt System and make sure the system is functioning as desired. Refer to the **Coapt COMPLETE CONTROL SYSTEM Gen2 Handbook** for details on configuring and calibrating.
6. Once control has been achieved, close the **Coapt COMPLETE SYSTEM Gen2 COMPANION** Mobile App, and disconnect power to the prosthesis..
7. Make note of any modifications to the check socket for comfort or fit. Make these modifications and repeat Steps 4-7 to ensure functionality.
8. Attach a prototype forearm to the socket to obtain correct length and alignment.
9. Attach the Coapt System and terminal device to the forearm. Confirm functionality.
10. Index the forearm and inner sockets.
11. Doff the socket and the liner.

## DEFINITIVE SOCKET FABRICATION

1. Fabricate a definitive socket using the same principles as the check socket. The final socket should have smooth, flowing contours and no sharp edges. The inside of the socket must be perfectly smooth with no sharp edges.
  - a. During lamination, be sure to seal off the lock dummy. A PVA bag or clear vinyl tape is recommended. Apply the PVA bag first with screws removed, then apply vinyl tape, and then insert lubricated screws.
2. After the socket has cured sufficiently, proceed with forearm lamination using standard procedures. Be sure to use the Coapt lamination dummies and battery dummies.
3. Insert the lock into place. Use the M3 or M4 set screws to secure the lock to the inner socket.
4. Align the forearm socket and inner socket using the rivet attachment holes. Transfer the button hole location to the forearm socket.

5. Remove the forearm socket and drill out the button hole.
6. Choose a location for the LED indicator, if desired. This should be visible to the amputee while donning the prosthesis. Drill a 1/8" hole at the chosen location.
7. Begin to assemble the prosthesis, making sure to route all cables so they will not interfere with the button. A fiber optic cable is provided with the lock.
  - a. Carefully push one end of the fiber optic cable into the LED indicator hole on the lock, until it sticks in place. This may take multiple tries.
  - b. If the end of the cable becomes crushed or deformed, use a sharp blade or the flat edge of clippers to trim the cable. The end of the cable must be flat and circular in order to be installed.
  - c. Repeat these steps until the cable is installed.
8. Slide the inner socket into the forearm. Make sure to route the unattached end of the fiber optic cable through the drilled hole in the forearm socket.
9. Attach the forearm socket to the inner socket using standard procedures. Make sure the hole for the button aligns with the button in the inner socket. Screw the button in place.
  - a. If desired, you may grind the button down to match the forearm socket surface:
    - i. Mark the desired height on the button.
    - ii. Unscrew the button from the lock.  
Note: Grinding the button while it is still attached to the lock may damage the button and/or the lock.
    - iii. Without gripping the button by the threads, grind the surface of the button down to the mark.  
Note: Gripping the button by the threads may damage the threads.
    - iv. Re-install the button.
10. Push as much of the fiber optic cable as possible back into the forearm socket without kinking it, and mark the fiber optic cable at the socket wall. Pull the fiber optic cable approximately 1" out of the socket, and cut the cable at the mark as described in Step 7.b.
11. Install the LED cap onto the end of the fiber optic cable, and push the cable and cap into the hole in the socket until it sticks. If necessary, use superglue to hold the cap into the socket wall, being sure not to obscure the top of the clear cap.
  - a. Engage the liner with the lock, then power on the prosthesis. Receive a short beep and momentary green light flash on the Complete Calibrate Button. Receive a green light from the lock LED, this turns off after ~3 seconds. Refer to the Coapt COMPLETE CONTROL SYSTEM Gen2 Handbook more information on the various light and sound patterns made by the Coapt Calibrate Button.

## REPAIRING WORN SEAMS

Damage to the liner seams from wear can be repaired with the same process that is used for other Alpha Liners, as long as the damage does not expose any leads or electrodes.

**Note: If the damage to the liner exposes leads or electrodes, the amputee should discontinue use immediately and acquire a replacement liner to prevent injury.**

1. **If the thread is gone, but the fabric and gel are intact:**
  - a. Trim off any long threads or loose, abraded fabric to prevent sharp edges from forming.
  - b. Pull the fabric back together into its original position. Sew the edges of the fabric together if desired.
  - c. Apply instant adhesive to the entire worn area, extending 3 mm (1/8") past the worn area.
2. **If the fabric is eroded, but the gel is intact:**
  - a. Apply a cloth patch slightly larger than the worn area.
  - b. Apply instant adhesive as described above.
3. **If the gel has eroded through, repairs will not be effective.**

## TROUBLESHOOTING

WillowWood has partnered with Coapt to bring you the liner system to enhance your experience with the Coapt Complete Control System Gen2. If you are experiencing issues that do not appear in or are not fixed by the guide below, call customer support.

**If you are able to complete all three of the following tasks, the liner system is OK.** Please call Coapt Support at 844.262.7800 x2.

1. Engage the liner with the lock, then power on the prosthesis. Receive a short beep and momentary green light flash on the Complete Calibrate Button. Receive a green light from the lock LED, this turns off after ~3 seconds.
2. Connect the Coapt system with the Coapt Complete Companion mobile app
3. Display EMG signals in the Complete Companion mobile app that all appear to change with muscle activity. (If some signals are flat or noisy, refer to item 3 below.) "WillowWood Alpha Control" is displayed on app screen near signals.

If you are unable to complete these tasks, please refer to the following table for Troubleshooting. If you are still unable to resolve your issue, contact WillowWood Support at 1.800.848.4930 x6.

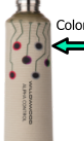
Problem	What It Means	Solutions
1. When I power on the prosthesis, I see a red light on the lock LED	Something is disconnected. Lock is not engaged.	Check that the liner is properly engaged with the lock. Upon turning on the power, the LED indicator should turn green for a few seconds, and then turn off. A red light indicates that the liner is not properly engaged with the lock (refer to item 2 below).
		Check that all cables are connected as per the <b>Coapt COMPLETE CONTROL Handbook</b> .
		If none of these fixes the problems, contact 844.262.7800, x2.
2. I'm having trouble engaging the lock.	The socket fit might be too tight.	A traditional skin fit system is often too tight for the liner system. Try to loosen the socket a bit. The socket fit around the epicondyles may also need to be loosened.
	Friction from a flexible inner layer may cause donning issues.	Reduce the thickness of the flexible inner layer.
	The module cap may have come loose.	Gently tighten the module cap with your fingers until it is snug.
3. The system connects, but the prosthesis doesn't operate as desired.	Electrode placement may not be optimal.	<p>Each electrode is associated with a line on the liner that connects to a colored dot.</p>  <p>These colors correspond to the colors of the channel displays in the <b>Coapt COMPLETE COMPANION</b> mobile app.</p> <p>Open the mobile app and view the signals from the prosthesis. If a particular channel is noisy or missing signals, check that the electrode associated with that color is securely inserted into the liner until finger tight, and that the electrode is located over a muscle belly and not on a bony prominence.</p>
	Calibration may need to be adjusted.	Refer to the <b>Coapt COMPLETE CONTROL Handbook</b> for assistance.
4. I see a red light on the Complete Calibrate button	Coapt experienced a power interruption which placed the unit into safe mode	Connect to the Coapt system with the Complete Companion mobile app and follow steps to reset the Coapt controller
5. I do not see EMG signals on the Coapt Complete Companion mobile app, only Xs	The liner is not being recognized by the Coapt Controller	<p>Check that the liner is properly engaged with the lock and power cycle the prosthesis</p> <p>Check that the lock connection cable is securely connected to the Coapt Controller and power cycle the prosthesis</p>



## REGULATORY INFORMATION



Connection of a PATIENT to a high frequency (HF) surgical equipment and to an ELECTROMYOGRAPH simultaneously may result in burns at the site of the ELECTRODES and possible damage to the APPLIED PARTS;



Operation in close proximity to a shortwave or microwave therapy equipment may produce instability in the APPLIED PARTS.



Do not touch the electrodes or leads to other conductive items.



Do not touch the electrodes or leads to electrically powered devices.

### Reporting a serious incident

In the event of a serious incident occurring as a direct consequence of using this medical device, which either directly, or indirectly caused (a) the death of the patient/user or another person, (b) the temporary or permanent serious deterioration of the patient's, user's or other person's state of health or (c) a serious public health threat, please immediately report the incident by contacting WillowWood Global or, if in the EU, the authorized European Union representative and the competent authority within the member state in which the patient/user is established.

### Warranty

WillowWood warrants each Alpha Control Liner from the date of patient fitting for a period of 6 months and the Alpha Control Lock and Alpha Control Module from the date of patient fitting for a period of 24 months against defects in material and workmanship. There is no warranty, expressed or implied, for damage caused by abuse, mishandling or accident. The warranty is void if the fitting and routine care instructions are not followed. For your protection and ours, please thoroughly clean all used products prior to return.

### Warranty Disclaimer

WillowWood warrants that each product manufactured will, at the time of delivery, be of workmanlike quality and substantially free of defects. WillowWood makes no other warranty, implied or expressed, and makes no warranty of merchantability or fitness for a particular purpose. This warranty shall terminate immediately upon an action to combine our products with other materials or in any manner change the nature of our products. The sole remedy is replacement of the products or credit for the products. If a replacement product is provided to a customer, the warranty period will be the number of days remaining on the original warranty. WillowWood's liability shall not exceed the purchase price of the product. WillowWood is not responsible for any indirect, incidental or consequential damage.

### Retention of Rights

WillowWood retains all intellectual property rights reflected in its physical products, regardless of the transfer of the physical products to another party or parties.



# WILLOWWOOD®

WillowWood Global LLC  
15441 Scioto Darby Road  
Mt. Sterling, OH 43143  
USA  
telephone 740.869.3377 / 800.848.4930  
**fax** 740.869.4374  
patent [www.willowwood.com/patents](http://www.willowwood.com/patents)



Emergo Europe  
Westervoortsedijk 60  
6827 AT Arnhem  
The Netherlands

