



## XtremityTT Socket System

### Instructions for Use

#### XtremityTT Socket System Overview:

The XtremityTT Socket has been developed to reduce fabrication time and improve outcomes compared to the traditional prosthetic socket. Our proprietary polymers contain carbon fiber for rigidity and strength. They are specifically designed to be easily formable.

The XtremityTT Benchtop Heating Unit heats the socket uniformly to the optimal forming temperature, while protecting the Distal Base from heat exposure.

XtremityTT Socket Preforms can be reheated and remolded up to 3 times. However, once the socket has been trimmed and finished, it cannot be completely reformed over a model. Adjustments can be made at any time by spot heating with a heat gun. If a patient's limb changes shape, the socket can be modified at any time throughout the lifetime of the socket without needing a new socket to be fabricated.

A practitioner can easily switch between Pin Lock, Suction, and Vacuum systems, as all suspension components use the same base.

The Distal Base accepts all four-hole components and has a built-in alignment system that allows for 8mm of slide and 15 degrees of rotation in any direction.

#### Table of Contents:

Guidelines and Precautions	2
System Parts Diagram	4
System Parts Key, Equipment list	5
Size Selection	6
Preparation, Heating and Forming	7
Forming Technique	9
Trimming and Finishing	11
Distal End Pad	11
Suspension System Options	16
Base Plate Assembly & Alignment	20
Socket Adjustments	22
Maintenance & Cleaning	22
Product Labeling	25

#### Product Identification:

Brand: XtremityTT™ Socket System



Category: Leg Prosthesis

**The patient should be informed of all information pertaining to the safe use of this product.**

**Indications for Use:**

- Unilateral or bilateral transtibial amputation
- Patient weight limit 275 lbs (125 kg) for moderate activity; 220 lbs (100 kg) for high activity
- Distal limb circumference between 26-37.9cm circumference (over a liner) at 4cm from distal end
- MPT circumference as indicated on page 6
- Patients that are likely to experience limb volume changes that will require socket modifications

**Contraindications for Use:**

- Limb length requiring a socket length over 29cm from the most proximal trimline to the distal end of limb
- Extremely bulbous or irregular limb shapes
- Socket shapes that exceed the build height and circumference limitations
- Wounds or skin issues that preclude normal fit
- Unusual alignment of the socket and foot
- Patients over 275 lbs (125 kg) for moderate activity or over 220 lbs (100 kg) for high activity
- Patients with amputation at or above the knee
- Patients who require socket trimlines that are lower than 2.5cm above MPT anteriorly or at MPT posteriorly, or that have sharp radii.
- Patients who engage in activities that could damage the proximal edge of the socket, such as kneeling with their socket directly on hard surfaces.

**Intended Use:**

The XtremityTT™ is intended to be used in combination with traditional prosthetic components to provide a complete prosthesis for use during activities of daily living. XtremityTT™ should only be provided under the direct supervision of a certified prosthetist. The device is for single patient use.

**Environmental Conditions:**

**Operating Temperature:** 0°F to 110°F (-17°C to 43°C)

**Storage Temperature:** 32°F to 100°F (0°C to 38°C)

**Warning:** The XtremityTT™ should not be exposed to ambient temperatures above 110°F or it may deform. While not in use, never store in a car or other environment where temperatures



can exceed 110°F. Store in a cool and shaded location and not in direct sunlight. Extended solar radiation can cause socket to exceed 110°F and deform.

## GENERAL SAFETY INSTRUCTIONS

### Warnings:

1. Failure to adhere to the guidelines of the *Instructions For Use* may cause product failure and will void the warranty.
2. Patient measurements must fit within the sizing guidelines. (page 6)
3. Do not exceed the weight limit.
4. The anterior trimline must cover the distal 1/3 of the patella (approximately 2.5 cm proximal to MPT).
5. Trimlines must be inspected for proper height and shape and should be free of any surface damage.
6. Sockets should be removed from the model by breaking out the plaster or foam model. Knocking the socket off the positive model with a block and hammer poses a risk of socket failure and voids the warranty.
7. Avoid direct socket contact with hard surfaces and wear protective kneepads if the patient spends significant time on their knees.
8. Socket and materials should not be reused between patients. Infection, injury, or damage to socket may occur.
9. If the device shows signs of damage or wear, hindering its normal functions, the patient should stop using the device immediately and contact their prosthetist or other healthcare professional.

### Precautions:

1. Only for use with a gel, silicone, or foam liner, or prosthetic sock.
2. Thermally protective clothing and gloves should be worn when handling the heated socket.
3. Only heat with the Xtremity Benchtop Heating Unit. Do not heat above 350°F (177°C).
4. The distal end base should never be heated.
5. When operating the Benchtop Heating Unit, allow 10 minutes of cool down time with the lid removed in between heating cycles or until the temperature inside the BHU is less than 125°F degrees.
6. Do not rapidly cool the socket.
7. Do not use an open flame to heat.
8. Do not grind the internal socket walls or base.
9. Do not drill holes or cut windows through the socket walls.
10. Use only included fasteners. Additional parts can be ordered.
11. Do not expose the product to chemicals or abrasive materials. Use soap and water or isopropyl alcohol to clean the surface.

**System Parts:**



Figure 1

### Parts Key

1. XtremityTT Socket Preform
2. Distal Base
3. Air Valve Filter
4. Suction Air Valve Base
- 4a. Suction Air Valve Base for DEP
5. Suction Bridge Assembly
6. Bridge Foam Spacer
7. Plunger Pin
8. Pin Lock Bridge Assembly
9. Air Hose Barb
10. Air Hose Filter
11. Air Hose (not included)
12. Bolt Ring
13. Base Plate
14. Base Plate Cover
15. M4 Socket Head Screws (4)
16. Lock Washers (4)
17. M6 Flat Head Screws (4)
18. Pyramid Adapter (not included)
19. Distal End Pad Injection Valve
20. Distal End Pad Valve Key

### Equipment and Tools Needed

- Xtremity Benchtop Heating Unit
- Measuring tape and marking pen
- Vacuum stand and vacuum pump
- Insulated gloves
- Latex sealing sleeve (for sealing socket against vacuum plate or pipe)
- Talcum powder, duct tape, nylon stockinette
- Silicone adhesive
- Hex wrenches: 3mm, 4mm, 8mm
- Cast saw
- Grinding and buffing tools
- Heat gun



**Size Selection Instructions for Xtremity sockets:**

Choosing the correct size XtremityTT Preform is critically important for optimal socket wall thickness and strength. XtremityTT Preforms are available in Standard and Conical Profiles. Sizing is determined using 3 measurements and the chart below.

1. **Distal Circumference:** First, take a circumferential measurement 4cm from the distal end of the limb model to determine the socket size (across the first row of the chart)
2. **Length:** Next, take a length measurement from the Mid-Patella Tendon (MPT) to the distal end of the limb model. Round to the nearest cm.
3. **Proximal Circumference:** Finally, take a circumferential measurement at MPT. Use the length and MPT circumference to determine the socket profile, Standard or Conical.

**Note:** Preforms for Size 26, 29 and 32 are available in Standard and Conical profile, Size 35 is Standard only.

**Note:** The total length from your most proximal trimline to the distal end must measure 29cm or less.

	MPT Circumference (cm):						
Distal Circumference	SIZE 26 <i>Distal 26-28.9cm</i>		SIZE 29 <i>Distal 29-31.9cm</i>		SIZE 32 <i>Distal 32-34.9cm</i>		SIZE 35 <i>Distal 35-37.9</i>
Limb Length: MPT to Distal End (cm)	Standard	Conical (+)	Standard	Conical (+)	Standard	Conical (+)	Standard
7	26.0 – 28.5	28.5 – 30.4	28.0 – 30.0	30.0 – 33.0	31.6 – 34.5	34.5 – 37.2	34.4 – 39.5
8	26.2 – 29.0	29.0 – 31.1	28.2 – 31.0	31.0 – 33.6	31.8 – 35.0	35.0 – 37.7	34.7 – 39.8
9	26.5 – 29.5	29.5 – 31.8	28.5 – 31.5	31.5 – 34.2	32.0 – 35.0	35.0 – 38.3	35.0 – 40.2
10	26.9 – 30.0	30.0 – 32.5	28.7 – 31.5	31.5 – 34.7	32.2 – 35.5	35.5 – 38.8	35.2 – 40.5
11	27.2 – 30.0	30.0 – 33.2	29.0 – 32.0	32.0 – 35.3	32.4 – 35.5	35.5 – 39.4	35.5 – 40.8
12	27.6 – 30.5	30.5 – 33.8	29.2 – 32.5	32.5 – 35.9	32.6 – 36.0	36.0 – 40.0	35.8 – 41.2
13	27.9 – 31.0	31.0 – 34.5	29.5 – 32.5	32.5 – 36.4	32.8 – 36.0	36.0 – 40.5	36.0 – 41.4
14	28.2 – 31.5	31.5 – 35.2	29.7 – 33.0	33.0 – 37.0	33.0 – 36.5	36.5 – 41.1	36.3 – 41.8
15	28.6 – 32.0	32.0 – 35.9	29.9 – 33.5	33.5 – 37.6	33.2 – 37.0	37.0 – 41.7	36.6 – 42.1
16	28.9 – 32.5	32.5 – 36.6	30.2 – 33.5	33.5 – 38.1	33.4 – 37.5	37.5 – 42.2	36.8 – 42.4
17	29.2 – 33.0	33.0 – 37.2	30.4 – 34.0	34.0 – 38.7	33.6 – 38.0	38.0 – 42.8	37.2 – 42.7
18	29.6 – 33.5	33.5 – 37.9	30.7 – 34.5	34.5 – 39.3	33.8 – 38.0	38.0 – 43.4	37.4 – 43.0
19	29.9 – 34.0	34.0 – 38.6	30.9 – 35.0	35.0 – 39.8	34.0 – 38.5	38.5 – 43.9	37.7 – 43.4
20	30.3 – 34.5	34.5 – 39.3	31.2 – 35.0	35.0 – 40.4	34.2 – 39.0	39.0 – 44.5	38.0 – 43.7
21	30.6 – 35.0	35.0 – 40.0	31.4 – 35.5	35.5 – 41.0	34.4 – 39.0	39.0 – 45.0	38.2 – 44.0
22	30.9 – 35.5	35.5 – 40.6	31.7 – 36.0	36.0 – 41.5	34.6 – 39.8	39.8 – 45.6	38.5 – 44.3
23	31.3 – 36.0	36.0 – 41.3	31.9 – 36.7	36.7 – 42.1	34.8 – 40.0	40.0 – 46.2	38.8 – 44.6
24	31.5 – 36.0	36.0 – 42.0	32.2 – 37.0	37.0 – 42.7	35.0 – 40.3	40.3 – 46.7	39.0 – 44.9
25	31.9 – 36.5	36.5 – 42.7	32.4 – 37.3	37.3 – 43.2	35.2 – 40.5	40.5 – 47.3	39.3 – 45.2
26	32.3 – 37.0	37.0 – 43.4	32.7 – 37.5	37.5 – 43.8	35.4 – 40.7	40.7 – 47.9	39.6 – 45.5

27	32.6 – 37.5	37.5 – 44.1	32.9 – 37.5	37.5 – 44.4	35.6 – 41.0	41.0 – 48.4	39.9 – 45.9
----	-------------	-------------	-------------	-------------	-------------	-------------	-------------

**Preparation:**

The XtremityTT Socket Preform is molded over a modified limb model using vacuum accompanied by hand forming. A vertical vacuum pipe or stand is preferred. However, the socket can be molded without vacuum by using aggressive hand forming with gloves while the socket is still hot.

**Properly preparing the limb model is critical for a successful pull and achieving distal contact.**

**Limb Shapes:**

Take additional circumferential measurements at the most proximal trimline and at levels with limb abnormalities to reference with the corresponding lengths on the sizing chart. If all measurements do not fall within the same size Preform, this limb may not be a good candidate for the XtremityTT Socket, unless additional modifications can be made to the limb model. (Fig. 2)

**Important Note: It is critical to use the correct size to assure the socket is not over stretched and that distal contact is achieved.**

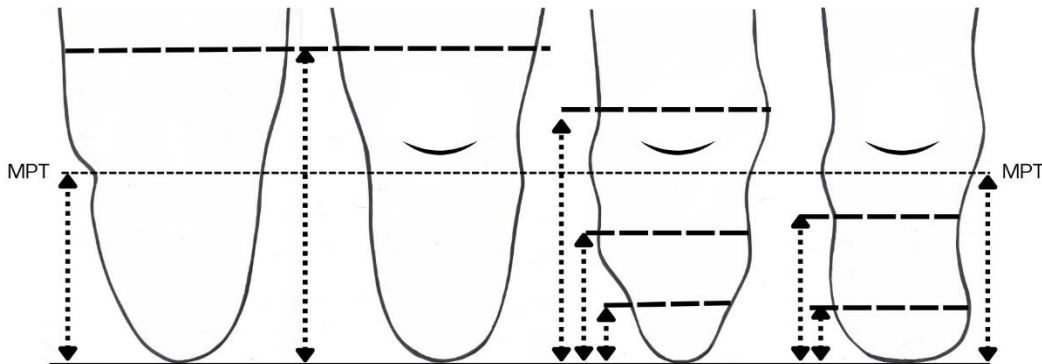

Figure 2

**Note:** It is important to maintain a rounded shape in general and avoid a large flat surface on the posterior wall as shown right. A flattened posterior area can result in socket weakness. (Fig. 3)

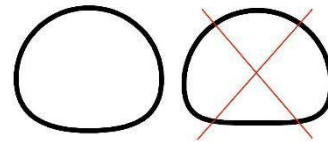

Figure 3

**Proximal Buildups:** Remove all proximal brim buildups and excess plaster proximal to the trimlines to prevent overstretching of the Preform and decrease resistance to achieving distal contact while pulling. (Fig. 4)



Figure 4

**Posterior Shelf:** If a posterior shelf is desired, trim the posterior trimline at least 6mm proximal to MPT and flare the finished socket for necessary contours. Posterior build ups and large patella build ups will make pulling and achieving distal contact difficult. (Fig. 5)



Figure 5

**Important note:** Alignment of the socket while pulling is key. The Xtremity logo should face anteriorly and the seam on the outside graphics must face posteriorly. The cutouts in the Distal Base cup should be oriented in the medial/lateral direction.

### Supplies Needed

1. Insulated Gloves
2. Duct Tape
3. Nylon Stockinette
4. Talcum Powder
5. Latex sealing sleeve or other sealing material
6. Base Plate
7. Foam Spacers

### Preparation:

1. Smooth the model. Apply nylon stockinette to the model.



2. Apply talcum powder to model/stockinette.
3. Place a latex sealing sleeve, or similar, over the vacuum stand.
4. Place the limb model on vacuum stand.
5. Add foam spacers under the model until the distal end of the model is over 30cm from the vacuum stand so the socket can fully seat onto the model. The socket preform should not touch the vacuum stand after pulled.

## Heating:

**Warning:** Heat the XtremityTT Preform only with the Xtremity Benchtop Heating Unit (BHU). Using other heating methods may result in damage to the socket and may void the warranty. Do not heat the Distal Base, doing so may affect the fit of the Base Plate and the compromise device safety. Allow for 10 minutes of cool down time with the oven lid off and socket removed in between heating cycles (BHU internal temperature must be 125°F or less).

1. Remove lid from the Heating Unit.
2. Place the Preform proximal end down, assuring visually that the silicone pedestal is centered properly on the distal end. Replace lid. (Fig. 6)
3. **For the 26 and 26+ sizes only**, which have a smaller Distal Base, place the rubber O ring provided over the distal end of the base to seal the opening. (Fig. 7)
4. Turn the BHU on by pressing the **POWER** button.
5. Ensure **SOCKET** is selected. The light above the **SOCKET** button should be on.
6. The display shows the selected maximum temperature. 350°F is the preset temperature and is recommended. (Fig. 8)
7. Verify the max temperature by Pressing **START**
8. The display shows the time the heating unit will hold at the maximum temperature. 5:00 minutes is the preset time and is recommended.
9. Verify the time at maximum temperature by pressing **START**.
10. The display will show the current temperature inside the Benchtop Heating Unit and is now heating up. Once the maximum temperature is reached (350°F) the display will start the countdown from the 5:00 minute time selected.
11. When the countdown finishes, the display will read “END” and a buzzer will sound.
12. Wearing insulated gloves, prepare to remove the socket. Work as quickly as possible after the timer alarms while



Figure 6



Figure 7

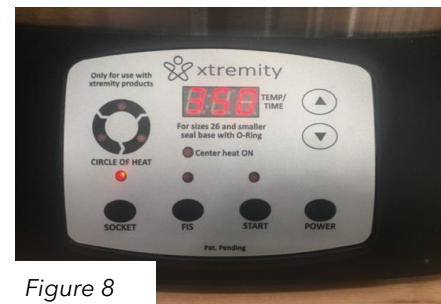

Figure 8

the socket is at its most formable state. There is three to five minutes of working time before the material starts to harden.

13. Remove oven lid (and O-ring, if using size 26 or 26+) and lift the socket by the Distal Base.

### Forming the XtremityTT without Distal End Pad:

Double check to ensure proper socket alignment. The seam on the graphic should face posterior (logo anterior) and the cutouts on the distal base should be oriented medial/lateral. Do not stretch socket directly along the graphic seam.

1. Using insulated gloves, remove socket Preform from the Benchtop Heating Unit by the Distal Base.
2. Apply talcum powder or silicone spray to the inside of the socket. (optional)
3. Note the length and shape of the limb model to determine if you need to stretch the socket further down onto the mold or just the proximal end to allow your fingers inside for pulling.
4. Identify the anterior logo on the outside of the socket to align with the anterior portion of the limb model. Using this logo, the posterior seam, and the medial and lateral Distal Base cutouts, ensure correct socket rotation.
5. Place all 4 fingers of each hand inside the Preform on the anterior and posterior aspect of the Preform and pull downward until it will not slide any further. (Fig.9)

**Note:** When pulling the socket, grasp the socket in areas that will fall outside of the trimlines (ie. the anterior and posterior proximal). This will prevent marring of the interior socket.

6. If not achieving distal contact, insert Base Plate into the Distal Base and push downward while simultaneously massaging the Distal Base transition to prevent material from bulging out in this area. (Fig. 10)
7. Confirm distal contact by looking or feeling through the threaded hole in the Distal Base. Notice that there is about a 1/4" of material beyond the last thread when judging if distal contact has been achieved by looking through the hole. The Distal Base angle



Figure 9



Figure 10

alignment can be adjusted slightly ensuring flexion/abduction angles are correct. Check that the Distal Base cutouts are aligned properly.

**Double check the alignment to ensure the release button will be in the proper position.**

8. Place a piece of duct tape over the threaded hole in the Distal Base. Using a latex sealing sleeve, create a seal between the vacuum stand and the outer surface of the socket. Apply vacuum for five minutes or until Preform is cool enough to place your hand on it and leave it there. (Fig. 11)

**Warning:** Do NOT rapidly cool the socket by quenching or by using compressed air. This could weaken the material causing socket failure.



Figure 11

#### **Important Information:**

- Ensure the finished socket does not have any bulges, wrinkles, nicks, or discontinuities.

#### **Repulling Preform:**

- If the first heating cycle resulted in an unsuccessful pull over the positive limb model, remove the preform from the limb model and allow to cool for about 5 minutes. Allow the Benchtop Heating Unit to cool for approximately 5 minutes with the lid off. Once cooled, you may place the same XtremityTT Preform back into the BHU for another heating cycle. Preforms can be reheated and remolded up to 3 times.
- Once the preform has been trimmed, you may NOT reheat the entire XtremityTT Socket in the BHU again. Spot heating using a heat gun only is allowed for thermal adjustments after the socket has been trimmed.

#### **Alignment:**

- Slight angular alignment adjustments can be achieved by tilting the Distal Base (no more than 5° in any direction) while preform is still hot on the limb model prior to pulling vacuum.
- High impact users with significant angular or offset alignment needs may not be good candidates for the XtremityTT socket.

### Trimming and Finishing without Distal End Pad:

1. Mark trimlines on the socket. Ensure the radii at the posterior corners are generous and the anterior trimline height extends at least 25 mm above the MPT (Fig. 13). Make the posterior trimline even with the MPT.
2. Finished posterior brim corners must provide smooth, generous curves for hamstring reliefs that seamlessly connect to the gradually sloping medial and lateral walls. (Fig.13)

3. Cut the socket using an oscillating saw (Fig. 12). Make a continuous rounded cut avoiding overcuts or sharp angles. Overcuts (incisions that extend from the main cut) can propagate into cracks when removed from the positive mold.
4. Remove socket from the model by breaking out the plaster or foam model. Use care when breaking out models to not damage the inner walls of the socket.
5. Grind and buff trimlines.
6. Use polishing arbors to completely smooth the proximal brim.
7. The proximal brim must be inspected closely prior to fitting on a patient. The presence of any cut marks or nicks at the brim could lead to socket failure.



Figure 12

**Warning: The anterior trimline must be at least 2.5cm proximal to MPT. Finished posterior brim shape must be at MPT level. Ensure posterior brim corners provide smooth, generous curves for hamstring reliefs that seamlessly connect to the gradually sloping medial and lateral walls. (Fig. 13). Failure to do so may result in product failure, injury, and voiding of the warranty. Do not grind or otherwise thin the socket walls.**

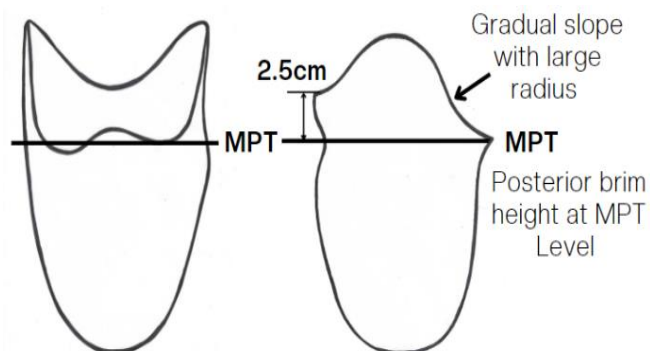

Figure 13

## Forming the XtremityTT with a Distal End Pad:

Double check to ensure proper socket alignment. The seam on the applique, or protective skin, should face posterior (logo anterior) and the cutouts on the Distal Base should be oriented medial/lateral.

**Note:** When pulling the preform, grasp the socket in areas that will fall outside of the trimlines (ie. the anterior and posterior proximal). This will prevent wrinkles or imperfections in the walls of the preform within the trimlines.

**Note:** Spray the DEP Injection Valve with Mold Release prior to taking the preform out of the Benchtop Heating Unit.

\*New BHUs have a hole cut out in the silicone pedestal that can accommodate installing the DEP Injection Valve prior to heating.

1. Wearing insulated gloves, remove socket Preform from the Benchtop Heating Unit by the Distal Base.
2. **Do Not Apply** talcum powder to the inside of the socket.
3. Screw in the DEP Injection Valve into the threaded distal hole using the DEP Injection Valve Key to aid in the process. \*Again, newer BHUs will allow the DEP Injection Valve to be installed prior to heating.
4. Note the length and shape of the limb model to determine if you need to stretch the preform further down onto the mold or just the proximal end to allow your fingers inside for pulling.
5. Identify the anterior logo on the outside of the preform to align with the anterior portion of the limb model. Using this logo, the posterior seam, and the medial and lateral Distal Base cutouts, ensure correct socket rotation
6. Place all 4 fingers of each hand inside the Preform on the anterior and posterior aspect of the Preform and pull downward until it will not slide any further. (Fig.14)

**Note:** When pulling the socket, grasp the socket in areas that will fall outside of the trimlines (ie. the anterior and posterior proximal). This will prevent marring of the interior socket.



Figure 14

6. If not achieving distal contact, insert Base Plate into the Distal Base and push downward while simultaneously massaging the Distal Base transition to prevent material from bulging out in this area (Fig. 15).
7. Confirm distal contact by pushing down onto the base with the Base Plate until a firm stop is felt. The Distal Base angle alignment can be adjusted slightly ensuring flexion/abduction angles are correct. Check that the distal base cut-outs are aligned properly.
8. Place a piece of duct tape over the Injection Valve opening in the Distal Base. Place DEP Injection Valve Key over duct tape to ensure it seals over the hole (Fig. 16). Using a latex balloon or sealing sleeve, create a seal between the vacuum stand and the outer surface of the preform. Apply vacuum for five minutes or until the socket is cool.



Figure 15



Figure 16

**Warning:** Do not rapidly cool the socket by quenching or by using compressed air. This could weaken the material causing socket failure.

#### **Important Information:**

- Ensure the finished socket does not have any bulges, wrinkles, nicks, or discontinuities.

#### **Repulling Preform:**

- If the first heating cycle resulted in an unsuccessful pull over the positive limb model, remove the preform from the limb model and allow to cool for about 5 minutes. Allow the Benchtop Heating Unit to cool for approximately 5 minutes with the lid off. Once cooled, you may place the same XtremityTT Preform back into the BHU for another heating cycle. Preforms can be reheated and remolded up to 3 times.
- Once the preform has been trimmed, you may NOT reheat the entire XtremityTT Socket in the BHU again. Spot heating using a heat gun only is allowed for thermal adjustments after the socket has been trimmed.

#### **Alignment:**

- Slight angular alignment adjustments can be achieved by tilting the Distal Base (no more than 5° in any direction) while preform is still hot on the limb model prior to pulling vacuum.
- High impact users with significant angular or offset alignment needs may not be good candidates for the XtremityTT socket.



## Distal End Pad Fabrication:

When using a non-locking liner, (any liner without a distal umbrella) common in suction and vacuum systems, a Distal End Pad (DEP) is recommended to achieve a distal end socket shape that matches the shape of the limb. The Distal End Pad is fabricated by injecting silicone into the distal end of the XtremityTT Socket. When planning to use a distal end pad, note there are a few differences in the Socket Shaping procedure.

### Equipment Needs (Fig. 17):

1. DEP Injection Valve
2. Injection Valve Key
3. Mold Release Spray
4. 400ml Smooth-On Body Double, Fast Set Silicone
5. Silicone Dispenser Gun with Mixing Tip
6. Rotary Cutting Stylus
7. 5/16" Hole Punch
8. Air Valve Filter
9. Distal End Pad Valve

If using vacuum, you will also need:

10. 5/32" Drill Bit
11. 10-32 NF Tap
12. Air Hose Filter



Figure 17

### Procedure:

1. Do NOT remove the socket from the limb model. Do NOT cut the trimlines.
2. Load the 400ml Smooth-On Body Double, Fast Set, Silicone cartridge into the dispensing gun and attach a new Static Mixer Tip.
3. Remove the tape from the hole in the DEP Injection Valve.
4. Ensure that mold release has been sprayed onto the DEP Injection Valve. (Fig. 18)



Figure 18

If using Vacuum, follow steps a-c below. If using Suction, skip to step 5.

- a. Use 5/32" drill bit to drill hole through the Vacuum port in the Distal Base. Use extreme caution not to make contact with the limb model or nylon.
- b. Remove the drill bit and place the smooth end into the hole just drilled until it contacts limb model. This will create a vacuum channel through the DEP. (Fig. 19)

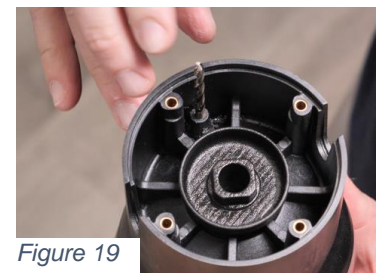

Figure 19

- c. Place a piece of duct tape over the 5/32" drill bit and the Distal Base. This will hold the drill bit in place during the silicone injection process.

5. Place the injection tip of the Silicone Dispenser Gun into the hole in the DEP Injection Valve. (Fig. 20)
6. Inject silicone into the void until the silicone has become pressurized in the void and begins to overflow.



Figure 20

7. Remove the Silicone Dispensing Gun and allow the Silicone to set for up to 15 minutes or until the silicone in the DEP Injection Valve cup has hardened. (Fig. 21)
8. Once the silicone has hardened, remove the Silicone Injection Adapter. If using Vacuum, remove 5/32" drill bit.
9. Place a 5/16" hole punch in the center of the distal threaded hole. Punch a hole through the silicone until the punch makes contact with the limb model. (Figs. 22 & 23)

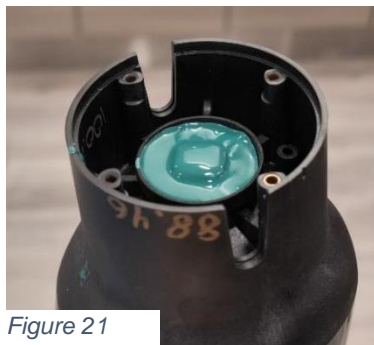

Figure 21



Figure 22



Figure 23

### Trimming and Finishing the Socket with Distal End Pad:

1. Mark trimlines on the socket. The anterior trimline must be at least 2.5cm proximal to MPT. Finished posterior brim height must be at MPT level. Ensure posterior brim corners provide smooth, generous curves for hamstring reliefs that seamlessly connect to the gradually sloping medial and lateral walls. (Fig. 13)
2. Cut the socket using an oscillating saw. Make a continuous rounded cut avoiding overcuts (incisions that extend from the main cut), nicks, or sharp angles, which can propagate into cracks.
3. Remove socket from the model by chiseling out of the plaster or foam model. Use care when breaking out models to not damage the inner walls of the socket.
4. Smooth and buff the proximal brim ensuring the outer surface of the brim is smooth, with no nicks or discontinuities.
5. The Silicone Distal End Pad will be adhered to the inside of the socket along with the vacuum nylon.



6. Using the Rotary Cutting Stylus, cut the excess nylon from around the inside of the socket along the proximal edge of the end pad. (Fig. 24)
7. If using Vacuum, ensure the vacuum channel is clear of silicone by removing excess silicone from vacuum hole.
8. Insert the Xtremity Air Valve Filter into the hole in the silicone. If using Vacuum, place Xtremity Vacuum Filter into vacuum hole. (Fig. 25 & 26)

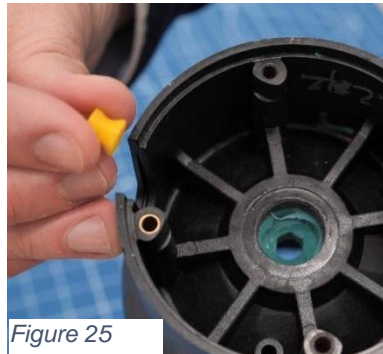

**Warning: The anterior trimline must extend a minimum of 2.5cm proximal to the MPT covering approximately 1/3 of the distal patella. Failure to do so may result in product failure, injury, and voiding of the warranty. Do not grind or otherwise thin the socket walls.**

### **XtremityTT Suspension Systems:**

The suspension systems can be changed by the practitioner at any time. Some modification to the socket fit may be needed when changing suspension systems.

#### **Suspension Options:**

- Pin Lock
- Suction
- Vacuum

### Pin Lock System: (Fig. 27)

**Warning:** Only use supplied Plunger Pin (7). Do not use Plunger Pins longer than 1-1/2.”

1. Align the assembled Pin Lock Bridge (6) so that the Release Button is oriented to the desired medial or lateral side.
2. Firmly push the Bridge into the Socket Base.
3. Insert the Bridge Foam Spacer (8) onto the bridge which allows easy replacement of the pyramid base.

The Pin Lock Bridge is provided pre-assembled. It should be disassembled and serviced on a regular basis to remove debris. To remove the Bridge, use a screwdriver or hex key to gently pry it from the Distal Base.



Figure 27

### Suction System without Distal End Pad: (Fig. 28)

The Suction System is to be used with a suspension sleeve or sealing liner.

1. Apply small amount of silicone adhesive to the threads of Suction Air Valve Base (4) prior to assembly.
2. Install the Suction Air Valve Base (4) into the socket from the proximal side using the 8mm hex driver. Compress or remove the filter as needed to install.
3. The Push Button Release Bridge (5) is provided pre-assembled. Insert the Push Button Release Bridge (5) into socket base and press firmly into place.
4. Test system for proper suction lock and release before use.
5. Insert the Bridge Foam Spacer (8) onto the bridge which allows easy replacement of the pyramid base.



Figure 28

**Note:** Inspect and clean the Suction Air Valve Base and filter regularly. Clean with isopropyl alcohol or compressed air.

### Vacuum System without Distal End Pad: (Fig. 29)

The XtremityTT Distal Base has a Vacuum Port that allows for the installation of an Air Hose Barb (9) directly into the socket. The port must be drilled and tapped before installation of the Air Hose Barb (9).



Figure 29



Figure 30

1. Using a 1/16" drill bit, drill a hole from the distal end, through the center of the Base Vacuum Port into the socket cavity.
2. Use a 10/32 tap to thread the Base Vacuum Port from the distal end.
3. Screw in a 10/32 Air Hose Barb (9)
4. Install the Air Hose (10) onto the Air Hose Barb (9).
5. Apply small amount silicone adhesive to the threads of (4) Air Valve Base prior to assembly.
6. Install Air Valve Base (4) into the socket using the 8mm. Compress or remove the air filter as needed to install.
7. Install the Push Button Release Bridge (5) into the XtremityTT Base slots.
8. Insert the Bridge Foam Spacer (8) onto the bridge. If needed, make a cut in the foam to allow the Hose (10) to have a pinch free route.
9. Pass Hose (9) through Base Plate and install. (Fig. 30)

### Suction with Distal End Pad:

1. Apply small amount of silicone adhesive to the threads of DEP Suction Air Valve Base prior to assembly.
2. Install the DEP Suction Air Valve Base into the socket using the DEP Injection Valve Key. (Fig. 31 & 32)
3. The Push Button Release Bridge (5) is provided pre-assembled. Insert the Push Button Release Bridge (5) into socket base and press firmly into place. (Fig. 33)
4. Test system for proper suction lock and release before use.

5. Insert the Bridge Foam Spacer (8) onto the bridge which allows easy replacement of the pyramid base.

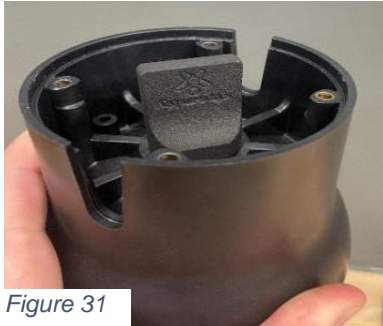

Figure 31

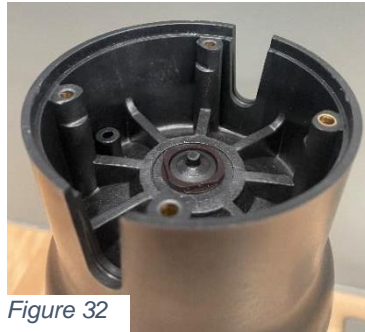

Figure 32



Figure 33

### Vacuum System with Distal End Pad: (Fig. 34)

1. Use a 10/32 tap to thread the Base Vacuum Port from the distal end.
2. Screw in a 10/32 Air Hose Barb (9)
3. Install the Air Hose (10) onto the Air Hose Barb (9).
4. Apply small amount of silicone adhesive to the threads of DEP Vacuum Air Valve Base prior to assembly.
5. Install DEP Air Valve Base into the socket using the DEP Injection Valve Key.
6. Install the Push Button Release Bridge (5) into the XtremityTT Base slots.
7. Insert the Bridge Foam Spacer (8) onto the bridge. If needed, make a cut in the foam to allow the Hose (10) to have a pinch free route.
8. Pass Hose (9) through Base Plate and install. (Fig. 30)



Figure 34

### Base Plate Assembly: (Fig. 35)

1. Apply liquid thread lock to the M6 Flat Head Cap Screws(17)  
**Note:** Some Pyramid Adaptors may require longer M6 Flat Head Cap Screws (17). Ensure screws thread all the way through the Bolt Ring (11). Pyramid adapters must have a flat surface that sits flush to the Base Plate Cover (13).
2. Insert the four M6 Flat Head Cap Screws (17) through the Pyramid Adapter (17), Base Plate Cover (13), and Base Plate (12) and loosely thread them into the Bolt Ring (11).
3. Choose rotational alignment for desired offset direction (sizes 26-35).
4. Press the Base Plate Assembly onto the Distal Base of the socket ensuring the holes in the Base Plate (12) align with the base screw holes in the socket.
5. Insert Lock Washers (16) onto the M4 Socket Head Screws (15).
6. Apply liquid thread lock to the four M4 Socket Head Screws (15), insert and torque to **3.8Nm**.
7. Adjust the Pyramid Adapter to the desired location.
8. Tighten the M6 Flat Head Cap Screws (17) to **13.2Nm**.

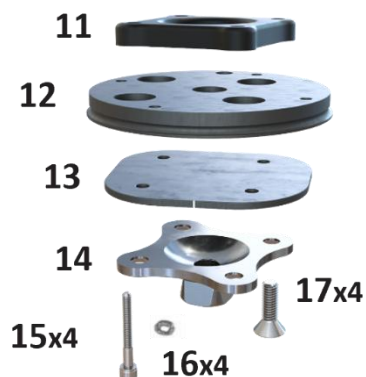

Figure 35

#### Torque settings:

Bolt	Torque (ft-lbs)	Torque (Nm)	Loctite 242	Silicone Sealant
M6 Flat Head Screws w/Thread Lock	9.7	13.2	yes	no
M4 Socket Head Screws w/Thread Lock	2.8	3.8	yes	no
Hose Barb	2.7	3.7	no	no
Pin Lock Collar Screws	0.7	1.0	no	no
Suction Air Valve Base	no	no	no	yes
Suction Air Valve Base for DEP	no	no	no	yes



### Base Plate Alignment:

- The Base Plate Assembly allows for linear slide adjustment, 8mm of total adjustment for the size 26 and 26+ and 16mm of total adjustment for the 29-35. The Base Plate grid (Figure 36) allows micro alignment to be annotated using an alpha-numeric grid system.
- The Base Plate Assembly used in the 29-35 sizes (not available in size 26 and 26+) allows the base plate assembly to be rotated in the socket base to allow an additional 8mm offset in the desired direction for a total of 16mm of adjustment. An engraved mark on the XtremityTT base (Figure 37) indicates the rotation chosen for documentation. The positions are numbered 1-4 so they may be recorded in the alpha numeric formula for realignment after disassembly for cleaning etc.



Figure 36



Figure 37

### Alignment Grid Adjustment Notation:

Note that there is an X and Y adjustment grid. The Pyramid Base is centered if the alignment indication marks correspond to position 0 (zero) and A on both grids (there is a small white dot to help indicate this) See Figure 38.



X-0-A, Y-0-A



X-3-B, Y-1-D



X-1-A, Y-4-D

Figure 38

**Always use this notation format for your records.**

### **Socket Adjustments:**

The XtremityTT shape can be modified with a heat gun to ensure proper fit. The walls and proximal edges of the socket can be heat manipulated. The material can be both pushed outward or inward after careful heating. The same area on the socket can be adjusted multiple times without marring the material or outer applique.

**Warning: Never use a torch or flame. Use thermal gloves and protective clothing when handling hot materials.**

1. Keep the heat gun moving while maintaining a distance of 2 or more inches from the socket. (Fig. 39)
2. Heat area for 2-3 minutes to 250°-300°F. Never exceed 350°F.
3. Using gloved hands or object, adjust the area's shape.

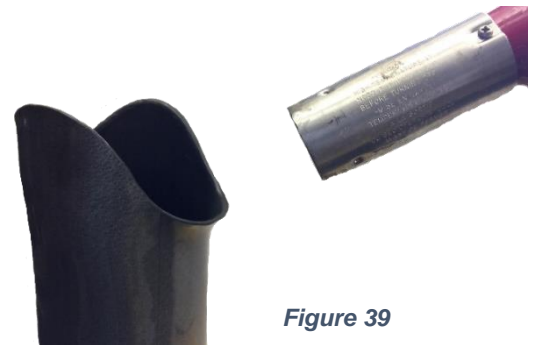

*Figure 39*

### **Maintenance & Cleaning:**

- All components should be inspected and cleaned every six months.
- Clean socket and components with isopropyl alcohol, mild soap and water or a damp cloth.
- Additional cleaning may be necessary if internal components are exposed to dust, sand, pet hair contaminants, or salt water.
- The Pin Lock Bridge and Suction Release Button Bridge Assembly should be regularly disassembled and cleaned of debris to maintain proper function. See below for detailed instructions or visit our website for maintenance instructions.
- The socket surface should be periodically inspected by the user for surface damage. Any damage should be immediately reported to the prosthetist.
- Frequent abrasion and damage to proximal edge may require a protective edge covering.
- Reapply thread lock and apply proper torque settings during reassembly as instructed.

### **Release Button Bridge Maintenance and Assembly:**

#### **Pin Lock Bridge (Fig. 40)**

The Pin Lock Bridge is provided pre-assembled. It should be disassembled and serviced on a regular basis to remove debris. First use a screwdriver or hex key to gently pry the Bridge from the Base.

**Assembly:**

1. Apply grease to the Push Button O-Ring (7) and slide the O-ring onto the Pin Lock Release Button (18).
2. Slide the Release Button Spring (9) onto the Pin Lock Release Button (18).
3. Insert the Pin Lock Release Button (18) into the Bridge (10). The spring must be fit into the proper slot in order to be pre-loaded, test it.
4. Apply grease to the Pin Lock Clip (16).
5. Insert the Pin Lock Clip (16) and Pin Lock Clip Spring (17) into the Bridge (15).
6. Attach the Pin Lock Collar (15) to the Bridge (10) using the 2 Pin Lock Screws (13). Tighten to Torque of 0.56 Nm and no more.
7. Apply the Pin Lock Collar O-ring (14) to the Pin Lock Collar (15).
8. Test before use. Attach Bridge Foam Spacer (11). Press assembled bridge firmly into the base.
9. **Note:** Inspect and clean the Suction Air Valve Base and filter regularly. Clean with isopropyl alcohol or compressed air.



Figure 40

**Suction Bridge (Fig. 41)**

The Push Button Release Bridge is provided pre-assembled. To remove, use a screwdriver or hex key to gently pry the Bridge from the Base.

**Assembly:**

1. Apply grease to the Push Button O-Ring (7) and slide the O-ring onto the Suction Release Button (8).
2. Slide the Release Button Spring (9) onto the Suction Release Button (8).
3. Insert the Suction Release Button (8) into the Bridge (10) with the flat side facing up.
4. Carefully engage the spring into the slot and test for smooth movement.
5. Install bridge into socket base and install Bridge Foam Spacer (11).

**Note:** Take care to assure flat section on Release Button (8) is aligned with the flat side up as shown. Test system for proper suction lock and release before use.



Figure 41







**Individual Replacement Part Names**





1. **Air Valve Filter**
2. **Vacuum Air Valve Base**
3. **Air Valve Base O-Ring**
4. **Air Hose Barb, straight - Optional**



5. **Suction Air Valve Base**
6. **Soft Air Valve**
7. **Release Button O-Ring**
8. **Suction Release Button**
9. **Release Button Spring**
10. **Bridge**
11. **Bridge Foam Spacer**
12. **Plunger Pin**
13. **Pin Lock Collar Screws (2)**
14. **Pin Lock Collar O-Ring**
15. **Pin Lock Collar**
16. **Pin Lock Clip**
17. **Pin Lock Clip Spring**
18. **Pin Lock Release Button**
19. **Bolt Ring**
20. **Base Plate**
21. **Base Plate Cover**
22. **Pyramid Adapter- *Optional***
23. **M4 Socket Head Screws (4)**
24. **M6 Flat Head Screws (4)**
25. **Lock Washers (4)**

Identification of symbols used on product labeling:

Symbol	Meaning or Definition
	Catalogue Number – Reference Number
	Serial Number
	Lot Number
	Date of manufacture
	Manufacturer: WillowWood Global 1662B N Lafayette St Denver, CO 80218 USA
	Consult the instructions for use for important warnings and precautions that are not on the device itself
	Consult instructions for use

	Keep away from sun/heat
	Keep dry
	Do not use if package is damaged
<b>Rx ONLY</b>	Prescription use only
<b>EC REP</b>	Authorized representative in the European Community
	Product is provided nonsterile
	Do not reuse between patients
<b>CE</b>	Self-certified in accordance with the European Medical Device Directive 2017/794
<b>MD</b>	Medical device

**CE**  WillowWood Global.  
1662B N Lafayette St  
Denver, CO 80218

**EC REP**  
MedNet EC-REP GmbH  
Borkstrasse 10,  
48163 Muenster,  
Germany